

AV09

LED Area Light

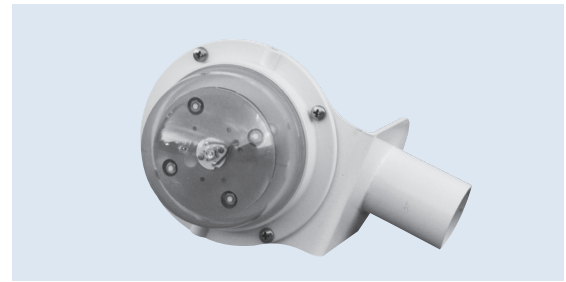

Applications

- 12v LED Area Light

The AV09 LED Area Light is a low-voltage area/compound light, designed to provide excellent ground or signage illumination.

Features

- CE Certified 
- 12v
- Area Illumination
- Sign Lighting
- Range of mounting brackets to accommodate pole, ceiling or wall mounting
- Domed luminaire with 3watt surface mounted ultra-high intensity LED for optimal area illumination (>120 degrees)
- Injection molded UV-stabilized LEXAN® polycarbonate lens and base
- Optional bracket assembly

Ordering Information

A V 0 9

Part Number: _____
AV09

Specifications

Light Characteristics	
Light Source	1x 3watt ultra-high intensity surface-mounted LED
Available colors	White
Peak Intensity (cd)*	>100
Horizontal & Vertical Divergence (degrees)	120
LED Life Expectancy (hours)	>100,000
Electrical Characteristics	
Current Draw (mA)	230 mA per light
Circuit Protection	Polarity protected
Operating Voltage (v)	12
Temperature Range	-40°F to +176°F (-40°C to +80°C)
Physical Characteristics	
Body Material	LEXAN® Polycarbonate – UV stabilized
Lens Material	LEXAN® Polycarbonate – UV stabilized
Mounting	4 x 6mm mounting holes
Weight (kg/lbs)	0.6 / 1.3
Product Life Expectancy	Up to 12 years

* Intensity setting subject to solar availability

Outline Drawing

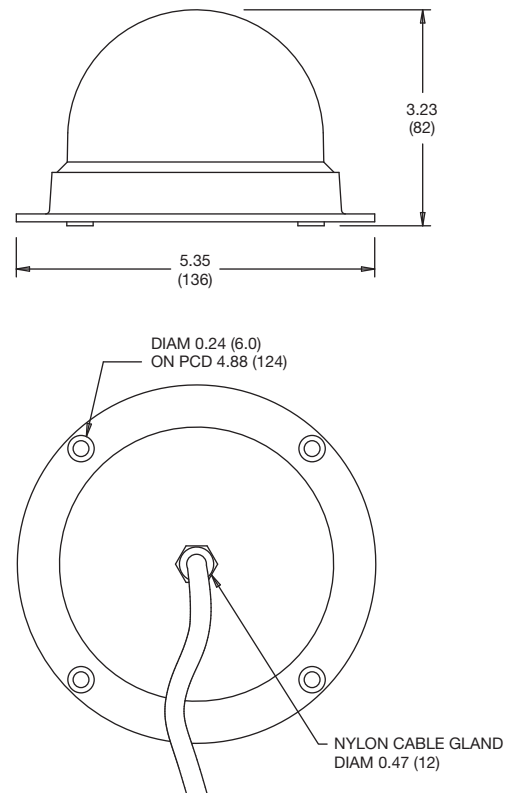

Dimensions: inches (mm)
Instruction Manual: Consult factory

Solar Aviation Light Products are manufactured by Avlite Systems, Victoria, Australia.

