

PRO III™ TCL 6 Taxiway Centerline Light

Compliances:
FAA AC 150/5345-46: L-852 D
UFC 3-535-01

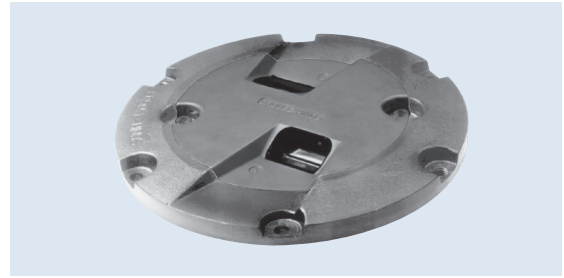

Applications

The TCL is a taxiway centerline light that is used primarily as a ground traffic aid during periods of low visibility to guide aircraft between the runway and the parking stand. The TCL is often a bidirectional light (using two 32 W lamps), but it also may be a unidirectional light (using one 32 watt lamp) on certain taxiways, such as high speed turnoffs.

Features



- ETL Certified
- Low profile, < .25" (6 mm) – FAA Style 3
- Unique combination of high-strength aluminum optical assembly and ductile iron outer ring for snow plow protection
- Low power consumption
- Few parts to stock
- Easy to maintain – no sealant required for prism or feed-through assembly replacement
- Pressure test plug for seal integrity verification
- Long lamp life – Quartz Halogen, 32 W

Ordering Information



Fixture Type: _____
D = L-852D (Wide, Cat. III)

Color Filters: _____
GX = Green/Blank YY = Yellow/Yellow
YX = Yellow/Blank GY = Green/Yellow
GG = Green/Green

Fixture Diameter: _____
12F = Optical assembly with 12" FAA support ring
NSR = Optical assembly without support ring
(See note 2; next page)

L-823 Plug Connection: _____
P1 = One plug (Blank color units will have a threaded cap installed.)
P2 = Two plugs (Two color units only. Note: For this feature only, blank is not considered a color.)

Options: _____
G = External gasket between optical assembly and support ring
(Note: Optical assemblies with external gasket will only fit support rings marked "G" on top surface.)

Outline Drawing

Dimensions:	inches (mm)
Instruction Manual:	2803
Shipping Weight:	23.0 lbs. 10.4 kg
Shipping Volume:	0.7 cu. ft. 0.02 m ³

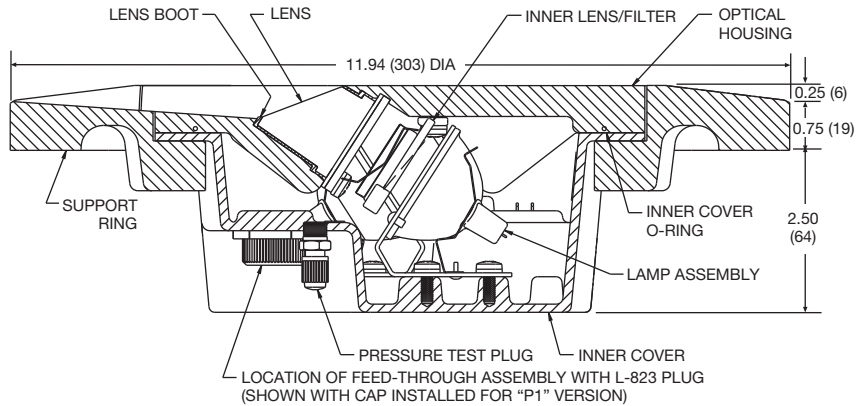

Typical Photometric Data

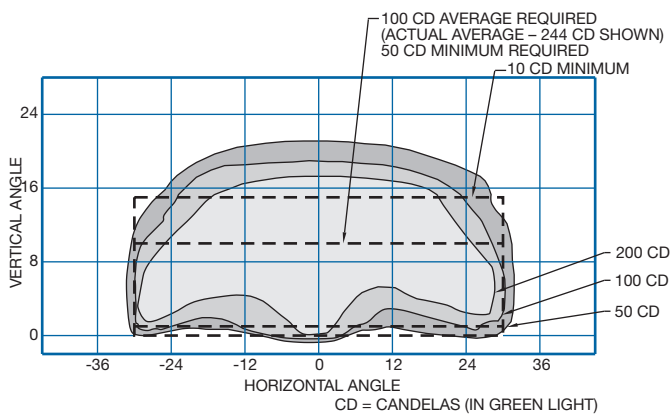

FAA L-852D , Wide (Curved Section), CAT III

Accessories

Item Description	Catalog Number	Item Description	Catalog Number
Base: L-868B, Class I*, 24" Deep	AC24242H200303	Isolation Transformer – 45 W, 20/6.6 A	33002
Connector Kit – L-823, 8 AWG, 0.32" to 0.43" O.D.	823KP-D4-D4	Isolation Transformer – 45 W, 6.6/6.6 A	33001
Heat Shrink Kit – 1 Piece	10047-2154	Isolation Transformer – 65 W, 6.6/6.6 A	33003
Heat Shrink Kit – 2 Piece	10047-1425	Lifting Tool (for outer ring)	19999

* Sectional bases may be required depending upon the paving technique

Renewal Parts

Description	Part Number	Description	Part Number
External support ring gasket	21180	Gasket – Bottom Cover	21124*
Feed-through Assembly – 1 Lamp, 1 Connector	21122	Lamp – 32 W, 6.6 A	21127
Feed-through Assembly – 2 Lamp, 1 Connector	21121	Lamp Bracket Assembly	21461
Filter – Green (wide)	21130-G	Lens Replacement Kit – Clear	21126-C
Filter – Yellow (wide)	21130-Y	O-Ring – Bottom Cover	10035-62*
Fresnel gasket	21132	Spare Optical Assembly	852D6-XX-NSR-XX

* For older unit without o-ring groove in top aluminum forging see instruction manual 2803.

Note:

1. Lens Replacement Kit includes lens, lens boot, lens retaining gasket, gasket lubricant, and lens retaining bracket and screws.
2. 852D6 fixtures and rings are not compatible with 852D3 fixtures and rings.

