

## SBL

### Elevated Stop Bar Light

Compliances:  
FAA AC 150/5345-46: L-862S



#### Applications

The SBL fixture is used for runway incursion protection and traffic control on taxiways just before active runways. It is required for SMGCS operations during low visibility conditions as defined in FAA AC 150/5340 and AC 120-57A. This unidirectional light is designed for use in all weather conditions with any kind of control system including the Digitrac® Control and Monitoring System.

#### Features



- ETL Certified
- Uses PK-30d low power consumption lamp
- Easy to install – mounts on a standard 2-inch (50 mm) mounting pipe with frangible coupling
- Mounting pipe extension included
- Easy to relamp – special tools are not required
- Cast aluminum housing
- Easy to aim
- Traffic signal red lens – eliminates need for separate filter
- Light head shipped fully assembled with lead assembly
- Control and Monitoring – Fixture can be supplied with a Crouse-Hinds Logitrac for individual lamp control and monitoring as required for flashing guard light operation or stop bar control. Contact Crouse-Hinds for more info

#### Ordering Information

**How to Order:** To the basic catalog number, add the height. A breakable coupling is required for proper mounting and is supplied with the fixture. Order base plate separately.

**Example:** 862S-14 is a red stop bar light 14-inches high.

Fixture Type: 8 6 2 S -

Height, Inches: \_\_\_\_\_

Standard Height 14 inches  
Available in 2-inch increments to 26 inches.

#### Typical Photometric Data

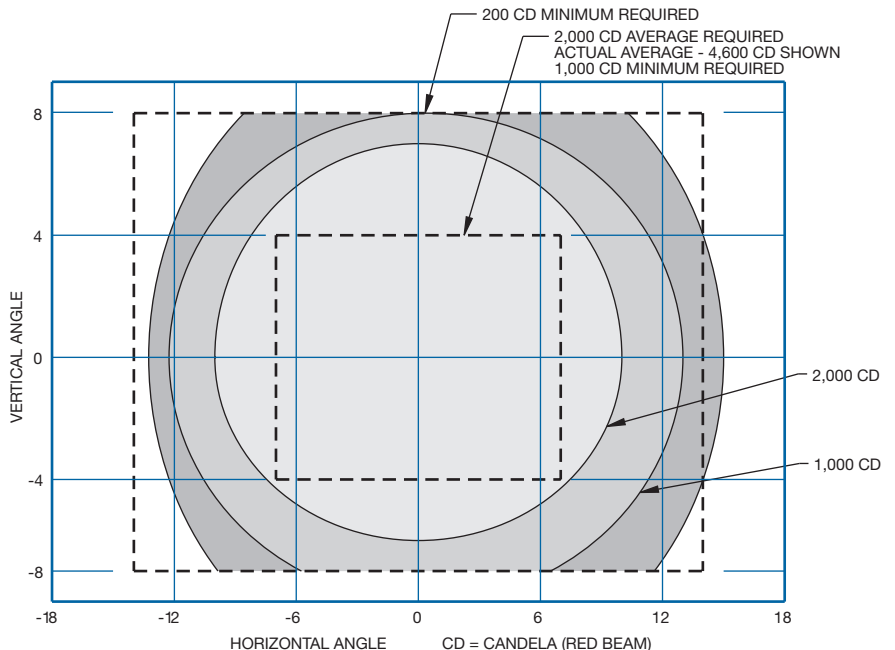

Typical photometric at 0° and 6.6 amps

## Outline Drawing

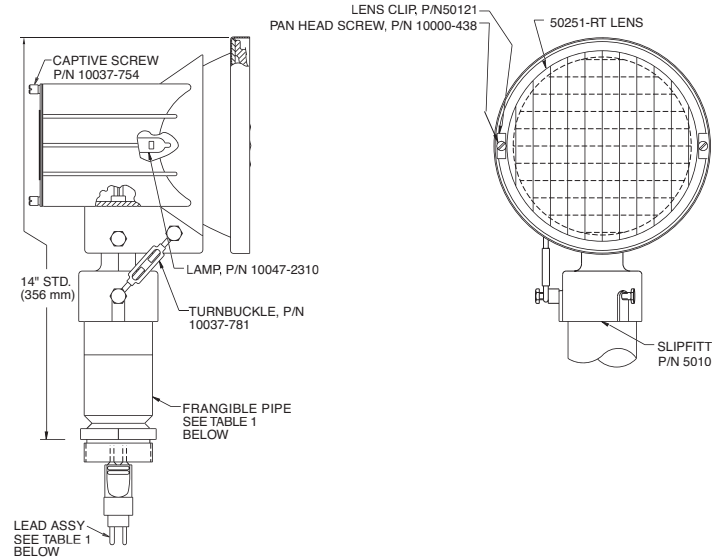

## Accessories

Description	Catalog Number	Shipping Weight		Shipping Volume	
		lb.	kg.	cu.ft.	cu.m.
Aiming Device (Optional)	50133	2.0	0.91	0.13	0.004
Base L867, Class I, 24" Deep	AC21242H200301	52.0	23.6	2.6	0.074
Baseplate, 2" Hub, 12" Diameter	AP1932	8.0	3.6	0.14	0.004
Connector Kit L-823, 8 AWG, 0.32" to 0.43" O.D.	823KP-D4-D4				
Heat Shrink Kit (1-piece)	10047-2154				
Heat Shrink Kit (2-piece)	10047-1425				
Isolation Transformer 150 W, 6.6/6.6 A	33150	8.9	4.04	0.3	0.009
Isolation Transformer 200 W, 6.6/6.6 A	33006	8.9	4.04	0.3	0.009

## Renewal Parts

Description	Part Number	Description	Part Number
Bolt, Slipfitter Hex	10A10-025D32	Lens Clip	50121
Captive Screw	10047-754	Lens, Traffic Signal Red	50251-RT
Frangible Pipe Extension (See Table 1)	50306 - X	Pan Head Screw	10000-438
Lamp, PK-30d, 150 W, 6.6 A	10047-2310	Slipfitter, Less Hardware	50106Y
Lead Assy., 6.6 A, (See Table 1)	50307 - X	Turn Buckle	10037-781

Table 1

Height Inches (mm)	Frangible Pipe Part No.	Lead Assembly Part No.
14 (355.6)	50306-1	50307-1
16 (406.4)	50306-2	50307-2
18 (457.2)	50306-3	50307-3
20 (508.0)	50306-4	50307-4
22 (558.8)	50306-5	50307-5
24 (609.6)	50306-6	50307-6
26 (660.4)	50306-7	50307-7

Instruction Sheet:	9818
Shipping Weight:	6.7 lbs 3.04 kg
Shipping Volume:	0.80 cu.ft. 0.024 cu.m.

