

TCLI

Taxiway Centerline Light - ICAO

Compliances:
ICAO Annex 14: Fig. A2.12 thru A2.16

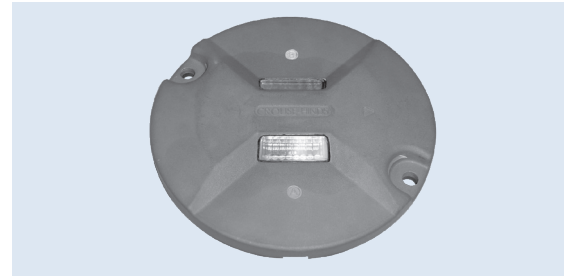

Applications

The TCLI-LED is a taxiway centerline light that is used primarily as a ground traffic aid during periods of low visibility to guide aircraft between the runway and the parking stand. The TCLI is often a bidirectional light (using either one or two lamps), but it also may be a unidirectional light (using one lamp).

Features

- ICAO Style 4, < 6 mm above grade
- High-strength aluminum housing
- Low power consumption
- Few parts to stock
- Easy to maintain — no sealant required for prism or feed-through assembly replacement
- Pressure test plug for seal integrity verification
- Shallow Base

Ordering Information



Fixture Type:
 C2 = Curved Sections, CAT II, Fig. 2.16
 C3 = Curved Sections, CAT III, Fig. 2.14
 N3 = Narrow Beam, CAT III, Fig. 2.13
 W2 = Wide Beam, CAT II, Fig. 2.15
 W3 = Wide Beam, CAT III, Fig. 2.12

Color Filters*:
 XG = Blank/Green YY = Yellow/Yellow
 GX = Green/Blank GY = Green/Yellow
 XY = Blank/Yellow YG = Yellow/Green
 YX = Yellow/Blank XR = Blank/Red
 GG = Green/Green RX = Red/Blank

L-823 Plug Connection:
 P1 = One plug, one lamp
 P2 = Two plugs, two lamps
 P3 = Three plugs, three lamps

* For fixture types C2 & C3, refer to the color filter designation: The first color is left toe-in; The second color is right toe-in.

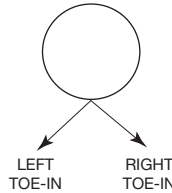

Fixture Type	Color
C2, C3	G, Y
N3, W2, W3	G, Y, R

Outline Drawing

Dimensions:	inches (mm)
Instruction Manual:	2620
Shipping Weight:	3kg
Shipping Volume:	0.01m ³

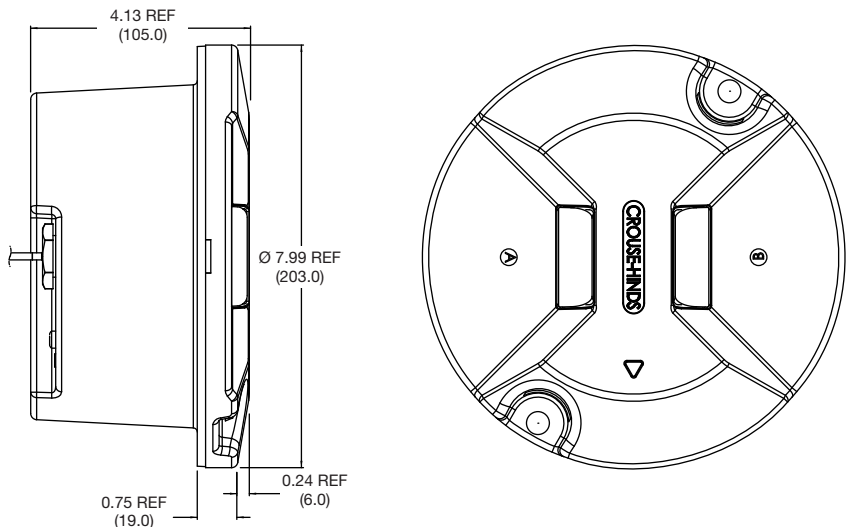

Typical Photometric Data:

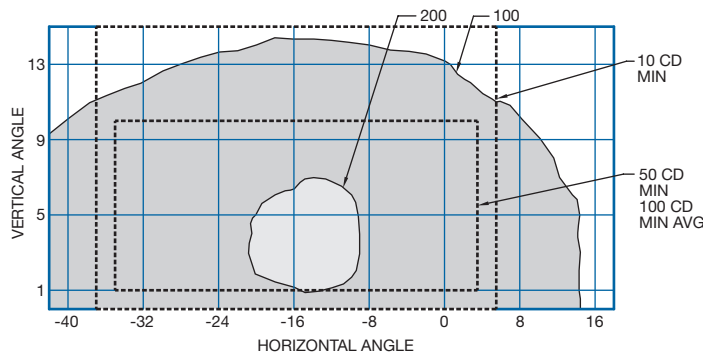

ICAO Figure A2.14, Curved Sections, CAT III
CD Avg: 165
Max/Min: 2.5

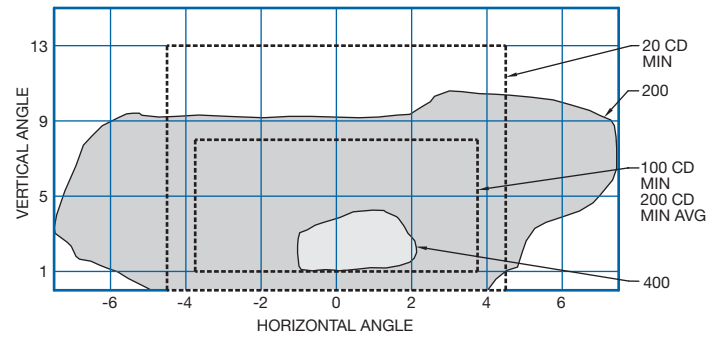

ICAO Figure A2.13, Narrow Beam, CAT III
CD Avg: 353
Max/Min: 1.7

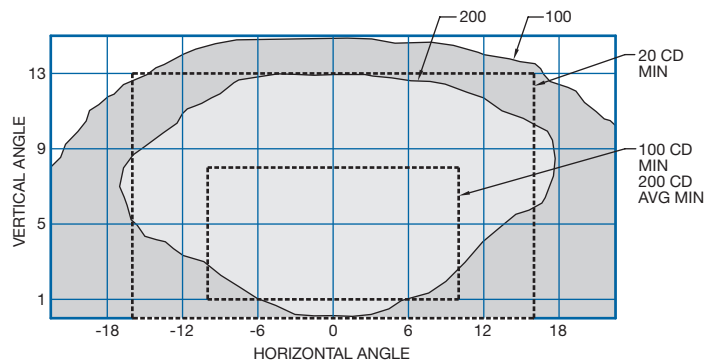

ICAO Figure A2.12, Wide Beam, CAT III
CD Avg: 245
Max/Min: 1.7

Accessories

Item Description	Catalog Number	Item Description	Catalog Number
Connector Kit – L-823, 8 AWG, 0.32" to 0.43" O.D.	823KP-D4-D4	Isolation Transformer – 100 W, 6.6/6.6A	33004
Heat Shrink Kit – 1 Piece	10047-2154	Isolation Transformer – 30/45 W, 20/6.6 A	33002
Heat Shrink Kit – 2 Piece	10047-1425	Isolation Transformer – 30/45 W, 6.6/6.6 A	33001
Isolation Transformer – 100 W, 20/6.6A	33005	Shallow Base	21390-X

Renewal Parts

Description	Part Number	Description	Part Number
Filter Boot	87014	Lens, Curved, Left (C2 & C3 fixtures)	87031-1
Green Filter	87006-G	Lens, Curved, Right (C2 & C3 fixtures)	87031-2
Isolator	87017	Lens, Straight (N3, W2, W3 fixtures)	87003
Lamp – 40 W, 6.6 A	87005	O-Ring	87018
Lens Boot (C2 & C3 fixtures)	87032	Red Filter	87006-R
Lens Boot (N3, W2, W3 fixtures)	87015	Yellow Filter	87006-Y
Lens Gasket	87016		

